

# A COMPARISON OF RESCHEDULING METHODS OF ACTIVE POWER GENERATION WITH REGARD TO STEADY STATE STABILITY LIMIT

Indar Chaerah Gunadin<sup>1,2</sup>, Adi Soeprijanto<sup>1</sup>, Ontoseno Penangsang<sup>1</sup>

<sup>1</sup>Institut Teknologi Sepuluh Nopember, Surabaya, <sup>2</sup>Universitas Hasanuddin, Makassar (INDONESIA)  
E-mails: indar09@mhs.ee.its.ac.id, adisup@ee.its.ac.id, zenno\_379@yahoo.com

## ABSTRACT

This paper discussed an active power generator scheduling in order to increase the limit level of steady state systems especially in the peak load condition. Some power generator optimization methods such as those of Langrange, Genetic Algorithm (GA), NN-GA, Merit Order, and the proposed Z-Thevenin-based were studied and compared in respect of their steady state aspects. A method proposed in this paper was a developed one based on the Thevenin equivalent impedance values between each load respected to each generator. These impedance values represented the point-to-point electric distance between a specific load and a related generator. Power generators with the closest impedance to the load were operated at the maximum level, followed by other generators. In this research, REI-Dimo was used to determine the steady state stability limit (SSSL). The steady state stability index values obtained through the various generator scheduling methods have been compared with the proposed method. As a study case, this research reviewed the 500kV-Jawa-Bali interconnection system. The simulation results showed that the proposed method required the highest operational cost; however, it had the highest limit level of steady state stability compared to other optimization techniques. Thus, the proposed method could be used to create the steady state stability limit of the system especially in the peak load condition.

**Key words:** generation scheduling, steady-state stability limit, REI Dimo, margin stability

## 1. INTRODUCTION

Nowadays, power systems are becoming heavily stressed due to the increased loading of the transmission lines. These problems lead to the steady state stability problem in the system. There are many of incidents in power system diagnosed as steady state stability problems caused by the increased loading and decreased stability margin. The stability margin may be defined as the distance between the loading of the system and the maximum loading limit of the system [1-3].

The problem in voltage instability has been the major cause for blackout cases all over the world recently [2]. Voltage stability is closely related with the steady state stability margin. If it has over limited to the maximum of power transfer, it leads to loss of operations of system and the voltage collapse will happen.

The need of power has been changing in every single day since the peak load occurs in early evening. The balance between power demand on power and power on generator must be carefully maintained [3]. Economic Load Dispatch or unit commitment is the method used to arrange power generation on each generator; therefore the operation cost is more economical [3-4].

Generator has input-output characteristics with the non linear trend. The mathematical determinant technique has problem with the non-linear solution. There have been a lot of methods developed for Economic Load Dispatch method, namely: Langrange Method, Merit Order and Artificial Intelligent [4]. The result of generator optimization gained from such method has influenced on system stability, especially on steady state stability.

Most of the available methods of generation rescheduling for steady state stability enhancement use optimization to determine the correct amount of rescheduling needed to drive the operating point away from the potentially dangerous situation. The effect of change in control variables on the steady state stability of the system is usually included in the optimization process in the form of linearized sensitivities of the steady state stability margin with respect to the parameters of interest [6-9]. This paper presents generator real power rescheduling considered as the means for enhancing steady state stability limit of a power system. The method proposed in this paper is built upon the Thevenin equivalent impedance between each load and each power generator. From the steady state stability review, power generators with lower impedance to the power load or the closest one will have a higher level of stability compared to those with higher impedance. This situation occurs as a result of maximum power transmission to the power load increases, hence, the limit level of the steady state stability increases as well. Power generators with the closest impedance to the load will be operated at the maximum level, followed by other generators. This arrangement should be made by referring to the sequence of Thevenin impedance values. Through this approach, the level of system stability will increase.

## 2. PROBLEM DESCRIPTION

Economic dispatch is very important to be considered in the planning and operation of power systems. However, the application of economic operation pattern sometimes makes the system have less secure stability. This research aimed to see the effects of optimization methods to the stability of steady state power system. Power scheduling method using Genetic Algorithm (GA), Neural Network-GA, Merit Order, Lagrange method will be compared with the proposed method. The influence of economic dispatch in steady state stability analysis was being concerned in this paper. It described that Dimo REI equivalent method was used to analyze the steady state

stability index. The computation of the reactive power criterion  $\frac{d\Delta Q}{dV}$  instead of evaluating the eigen values of the dynamic Jacobian determinant resulted in an increase of the computational speed by at least one order of magnitude and was at the core of the fast and relatively accurate technique developed by Paul Dimo [13]. Dimo's method has been successfully implemented and currently used in several SCADA/EMS installations to compute the system load ability limits in real time and to continuously monitor the distance to instability [13, 14, 15].

At the time of the generation pattern changes, there will be changes to the steady state stability index. With equation (1), the stability index for each change of the generation of operation can be calculated:

$$\frac{d\Delta Q}{dV} = \sum_m \frac{Y_m E_m}{\cos \delta_m} - 2 \left( \sum_m Y_m + Y_{load} \right) V \quad (1)$$

where:

$E_m$  = internal voltages of the machines (assumed to remain constant, unaffected by small adjustments made under steady-state stability conditions)

$\delta_m$  = internal angles of the machines with reference to the voltage  $V$  on the load bus (either fictitious or actual)

To simplify, the formula in equation (1) will be separated into two components, such as :

$$D = \sum_m \frac{Y_m E_m}{\cos \delta_m} \quad \text{and} \quad E = 2 \left( \sum_m Y_m + Y_{load} \right) V \quad (2)$$

To determine the pattern of economic relations represented on the stability index value  $\frac{d\Delta Q}{dV}$  is determined by changes in the parameters of  $V$  and  $\cos \delta_m$ . The closer the distance load to the power plant that supplies the value  $\cos \delta_m$ , the greater the difference angle bus that sends and receives the smaller one, the result will be worth the value of  $D$  and  $E$  will be smaller, but greater value. The small value of  $D$  and the greater value of  $E$  resulting in the distance to  $D = E$  or  $\frac{d\Delta Q}{dV} = 0$  becomes more distant. So, this method can increase the steady state stability limit.

The value of steady state index obtained from equation (1) describes the condition of system stability. The pattern of active power generation obtained from the GA, NN-GA, Merit Order, Lagrange optimization and Z Thevenin is then compared in order to know which one is the best pattern of steady state stability limit index.

### 3. METHODOLOGY

#### A. DIMO'S APPROACH

The theoretically oriented reader is directed to review reference [8], in which more subtle aspects of Dimo's methodology are addressed in detail, including the generalization of Dimo's formulation of the reactive-power steady-state stability criterion. The transformation of a meshed power system network to an REI net can be applied to an actual load bus, to connect it radially with all the generators by means of short-circuit admittances, as shown in Figure 1.

The buses are numbered sequentially as follows:

1... m.. G generator buses (either on the generator's terminals or on the high voltage side of the step-up transformer).

i...N load buses where, for convenience,  $G + 1$  is noted as  $i$  and corresponds to the load bus  $L_1$  (Figure 1).

By changing the sign of these linearized admittances, adding them to the diagonal elements in  $Y$ , and performing the Gauss-Seidel elimination of all the linear buses except  $L_1$ , a new matrix  $Y'$  of order  $(G + 1) \times (G + 1)$  is obtained, and a new system configuration can be constructed using the new matrix  $Y'$  as shown in Figure 4. The following equation will explain this concept:

$$I_{L1} = \sum_{i=1}^G Y'_{L1i} V_i + Y'_{L1L1} V_{L1} \quad (3)$$

where

$$Y'_{L1L1} = Y_{L1L1} - \sum_{i=1}^G Y'_{iL1} \quad (4)$$

$y'_{L1L1}$  being the bus-to-ground admittance at the bus  $L_1$ .

From equation (3) and (4) will obtain:

$$I_{L1} - Y'_{L1L1} \cdot V_{L1} = \sum_{i=1}^G Y'_{L1i} \cdot V_i - \left( \sum_{i=1}^G Y'_{iL1} \right) \cdot V_{L1} \tag{5}$$

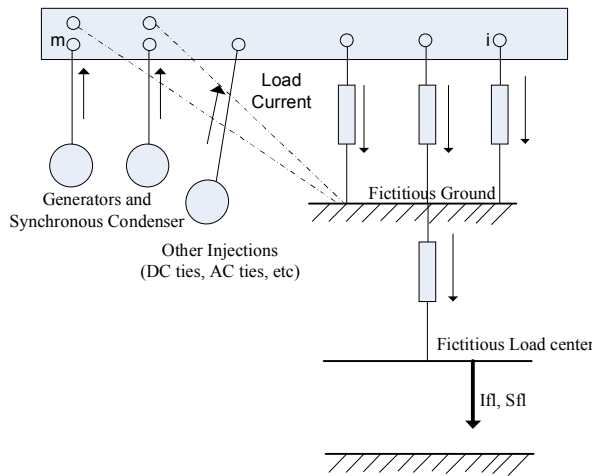

**Fig. 1.** Transition from the meshed power system network to the radial scheme of short-circuit admittances, also known as the REI net.

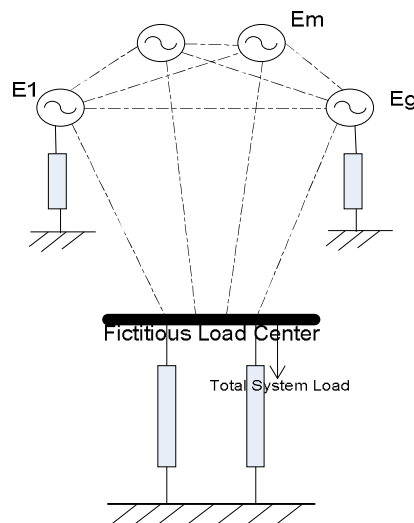

**Fig. 2.** REI nets with a fictitious load center

**B. ESTABLISH Z THEVENIN MATRIX**

For example: A power system consists of three generators and three loads. Illustration of the system can be described in figures (3).

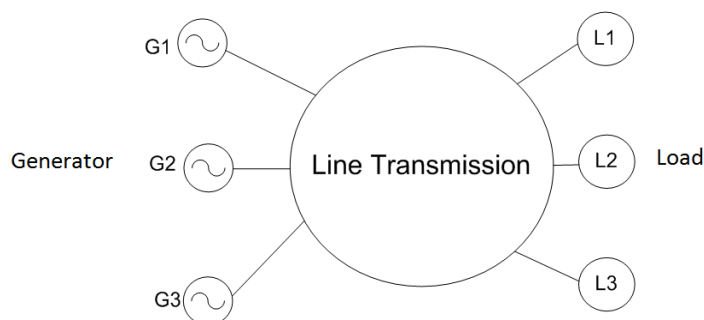

**Fig. 3.** System Illustrations Schema

Current and voltage equations are formed:

$$[I]=[Y][V] \quad (6)$$

or

$$[V]=[Z][I] \quad (7)$$

The sequence of bus number started from generator bus to load bus. Furthermore, the matrix of voltage system is obtained as follows:

$$\begin{bmatrix} V_1 \\ V_2 \\ V_3 \\ V_4 \\ V_5 \\ V_6 \end{bmatrix} = \begin{bmatrix} Z_{11} & Z_{12} & Z_{13} & Z_{14} & Z_{15} & Z_{16} \\ Z_{21} & Z_{22} & Z_{23} & Z_{24} & Z_{25} & Z_{26} \\ Z_{31} & Z_{32} & Z_{33} & Z_{34} & Z_{35} & Z_{36} \\ Z_{41} & Z_{42} & Z_{43} & Z_{44} & Z_{45} & Z_{46} \\ Z_{51} & Z_{52} & Z_{53} & Z_{54} & Z_{55} & Z_{56} \\ Z_{61} & Z_{62} & Z_{63} & Z_{64} & Z_{65} & Z_{66} \end{bmatrix} \begin{bmatrix} I_1 \\ I_2 \\ I_3 \\ I_4 \\ I_5 \\ I_6 \end{bmatrix}$$

To determine impedance (Z) thevenin between  $G_2$  generator and  $L_2$  load, then the value of  $I_1=I_3=I_4=I_5=0$ , this is due to  $G_1$  and  $G_3$  generator are not supplying current.

Voltage equation becomes :

$$\begin{bmatrix} 0 \\ V_2 \\ 0 \\ 0 \\ 0 \\ 0 \end{bmatrix} = \begin{bmatrix} Z_{11} & Z_{12} & Z_{13} & Z_{14} & Z_{15} & Z_{16} \\ Z_{21} & Z_{22} & Z_{23} & Z_{24} & Z_{25} & Z_{26} \\ Z_{31} & Z_{32} & Z_{33} & Z_{34} & Z_{35} & Z_{36} \\ Z_{41} & Z_{42} & Z_{43} & Z_{44} & Z_{45} & Z_{46} \\ Z_{51} & Z_{52} & Z_{53} & Z_{54} & Z_{55} & Z_{56} \\ Z_{61} & Z_{62} & Z_{63} & Z_{64} & Z_{65} & Z_{66} \end{bmatrix} \begin{bmatrix} 0 \\ I_2 \\ 0 \\ 0 \\ 0 \\ I_6 \end{bmatrix}$$

or:

$$[V_2]=[Z_{21}][0]+[Z_{22}][I_2]+\dots+[Z_{26}][I_6] \quad (8)$$

$$[V_2]=[Z_{22}][I_2]+[Z_{26}][I_6] \quad (9)$$

Current magnitude  $[I_6]=-[I_2]$ , because the total current coming out of the generator equal to the total current flowing to the load but with different directions.

Then obtained:

$$[V_2]=([Z_{22}]-[Z_{26}])[I_6] \quad (10)$$

Thevenin circuit from power source generator  $G_2$  to the load  $L_2$  can be described as follows:

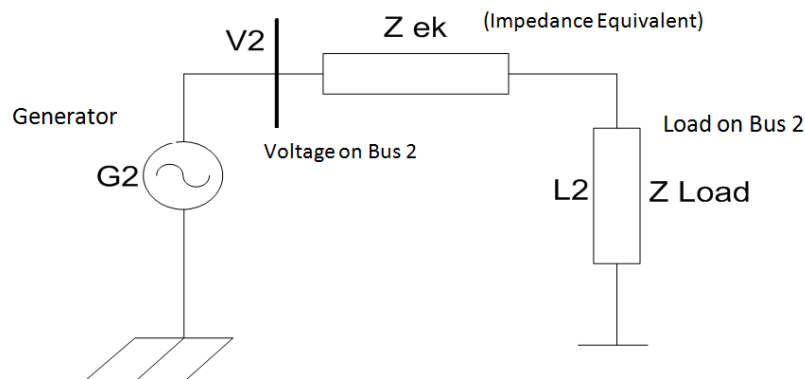

**Fig. 4. Thevenin Circuit**

$$[V_2]=([Z_{ekv}]+[Z_{load}])[I_2] \quad (11)$$

$$([Z_{22}] - [Z_{26}]) = ([Z_{ekv}] + [Z_{load}]) \quad (12)$$

Thus obtained:

$$[Z_{ekv}] = ([Z_{22}] - [Z_{26}]) - [Z_{load}] \quad (13)$$

**Table 1.** Correlation Between Load and Impedance

Load\Gen	G <sub>1</sub>	G <sub>2</sub>	G <sub>3</sub>
L <sub>1</sub>	Z <sub>11</sub>	Z <sub>12</sub>	Z <sub>13</sub>
L <sub>2</sub>	Z <sub>21</sub>	Z <sub>22</sub>	Z <sub>23</sub>
L <sub>3</sub>	Z <sub>31</sub>	Z <sub>32</sub>	Z <sub>33</sub>

Where:

L<sub>i</sub> = Load demand

G<sub>i</sub> = Generator

Z<sub>ij</sub> = thevenin impedance.

The generator that will be operated depends on value of load (L<sub>1</sub>, L<sub>2</sub>, L<sub>3</sub>). Supposed load demand was L<sub>1</sub> in the system, the generation plant closest to the load (L<sub>1</sub>) will operate first or the one which has the smallest value of thevenin impedance (from the matrix above).

#### 4. SIMULATION

This research started with collected power system data, and then the economic dispatch was observed with various methods such as: GA, NN-GA, Merit Order, Lagrange and proposed methods. Figure 5 explained the algorithm of this research.

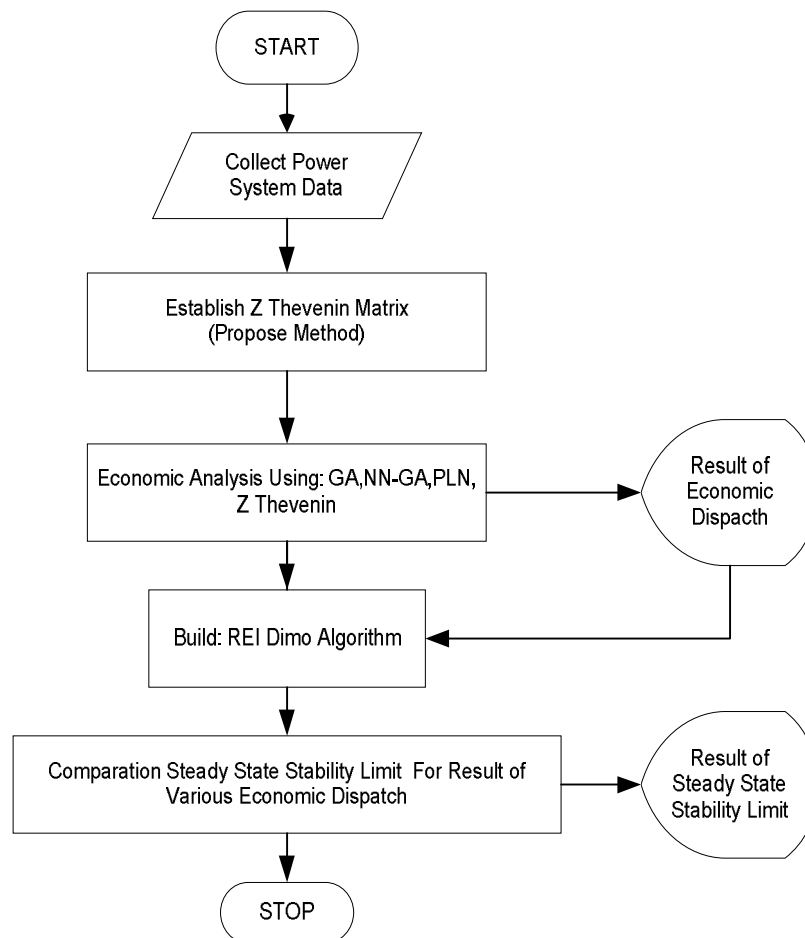

**Fig. 5.** Algorithm of Simulation

#### 4.1. Data Of Java-Bali Power System

The Plant as case for simulation is the 500 kV Java-Bali Power System as shown in Fig. 1. The data of generator characteristics, line impedances and an operating condition are shown at Tables 2-3.

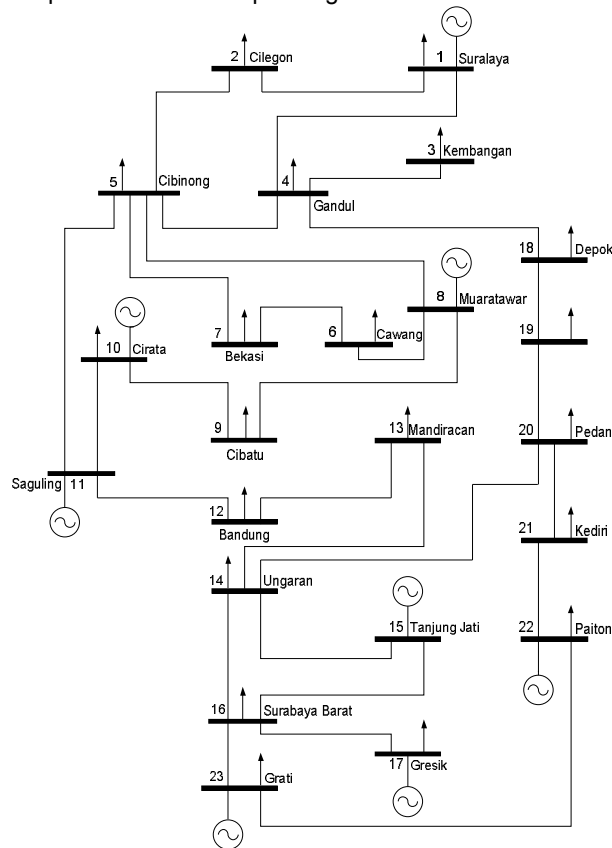

Fig. 6. Single Line Diagram of 500 kV Java-Bali Power System

Table 2. Line Data of 500 kV Java-Bali Power System

From Bus	To Bus	R (pu)	X (pu)	B (pu)
1	2	0,000626496	0,007008768	0
1	4	0,006513273	0,062576324	0,01197964
2	5	0,013133324	0,146925792	0,007061141
3	4	0,001513179	0,016928309	0
4	5	0,001246422	0,01197501	0
4	18	0,000694176	0,006669298	0
5	7	0,00444188	0,0426754	0
5	8	0,0062116	0,059678	0
5	11	0,00411138	0,04599504	0,008841946
6	7	0,001973648	0,01896184	0
6	8	0,0056256	0,054048	0
8	9	0,002822059	0,027112954	0
9	10	0,00273996	0,026324191	0
10	11	0,001474728	0,014168458	0
11	12	0,0019578	0,0219024	0
12	13	0,00699098	0,0671659	0,01285827
13	14	0,013478	0,12949	0,024789624
14	15	0,01353392	0,15140736	0,007276522
14	16	0,01579856	0,1517848	0,007264438
14	20	0,00903612	0,0868146	0
15	16	0,037539629	0,360662304	0,017261339
16	17	0,00139468	0,0133994	0
16	23	0,003986382	0,044596656	0
18	19	0,014056	0,157248	0,030228874
19	20	0,015311	0,171288	0,032927881
20	21	0,010291	0,115128	0,022131855
21	22	0,010291	0,115128	0,022131855
22	23	0,004435823	0,049624661	0,009539693

**Table 3.** Operating Condition

Bus No.	Load		Generation		Injected Mvar
	MW	Mvar	MW	Mvar	
1	153	45	3332.176	988.564	0
2	703	227	0	0	0
3	760	261	0	0	0
4	544	181	0	0	0
5	697	215	0	0	0
6	760	181	0	0	0
7	646	170	0	0	0
8	0	0	1470	679.361	0
9	823	317	0	0	0
10	680	245	400	484.322	0
11	0	0	535	1043.085	0
12	590	351	0	0	0
13	397	136	0	0	0
14	329	363	0	0	0
15	0	0	830	361.87	0
16	862	317	0	0	0
17	210	91	810	608.616	0
18	0	0	0	0	0
19	277	17	0	0	0
20	524	244	0	0	-158
21	358	206	0	0	-193
22	839	272	2820	895.043	-96
23	130	193	198	395.97	0
Total	10282	4032	10395.18	5456.832	-447

## 5. RESULTS AND DISCUSSION

### 5.1. Economic Dispatch Result

The simulation results obtained from economic dispatch with NN-GA method had the lowest operating cost compared to another methods of economic dispatch, followed by: GA, Merit Order, and Thevenin respectively. This is illustrated in Figure 7.

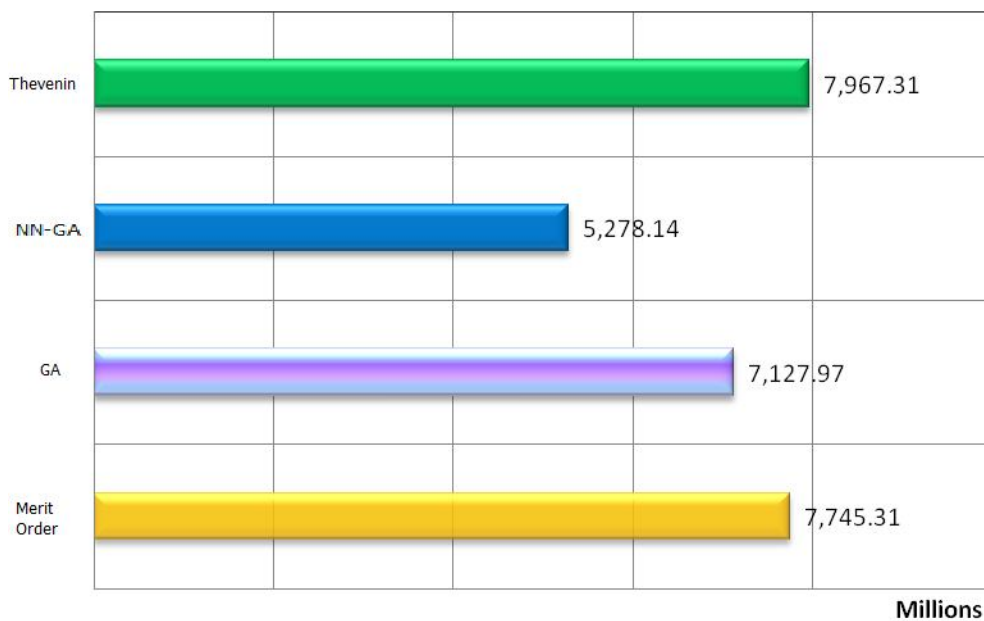

**Fig. 7.** Comparison of Total Operating Cost

### 5.2. Steady State Stability Result

In this simulation the value of steady state stability limit (SSSL) for every plant optimization methods was determined. In Figure 8, it was shown that the Thevenin equivalent method had the value of SSSL greatest value compared with the others: Lagrange, Merit Order, Z Thevenin methods and was capable of improving the condition of the system stability. So, this method was necessary especially at peak load operating conditions close to unstable condition. In table IV, looking for operations using Z Thevenin it was obtained the SSSL value of 18.126 MW, followed by the Lagrange method (17.497 MW), and Merit Order (16.319 MW).

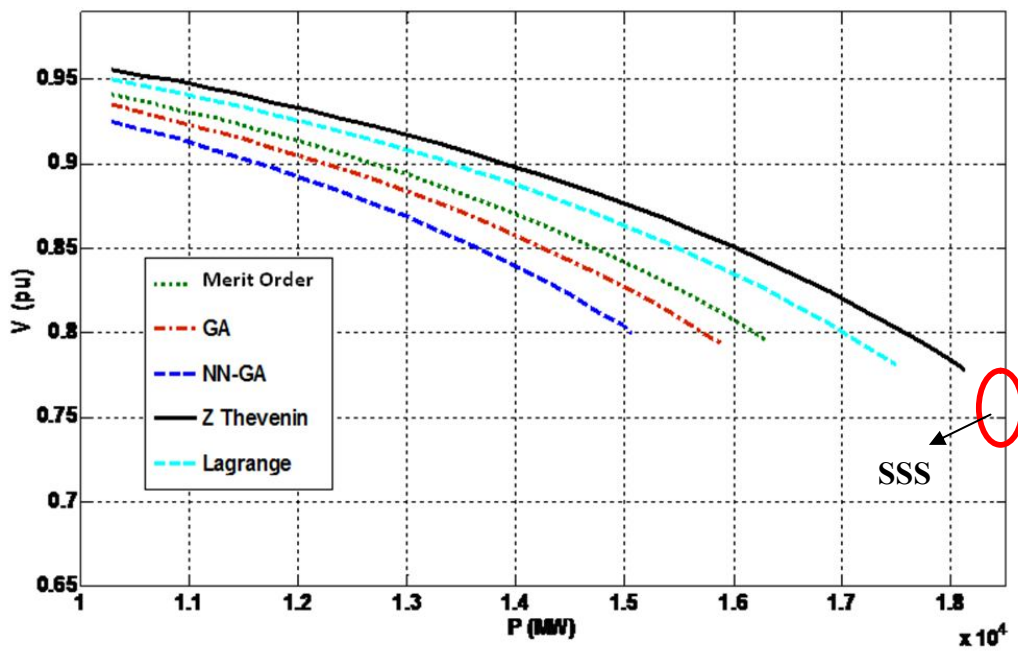
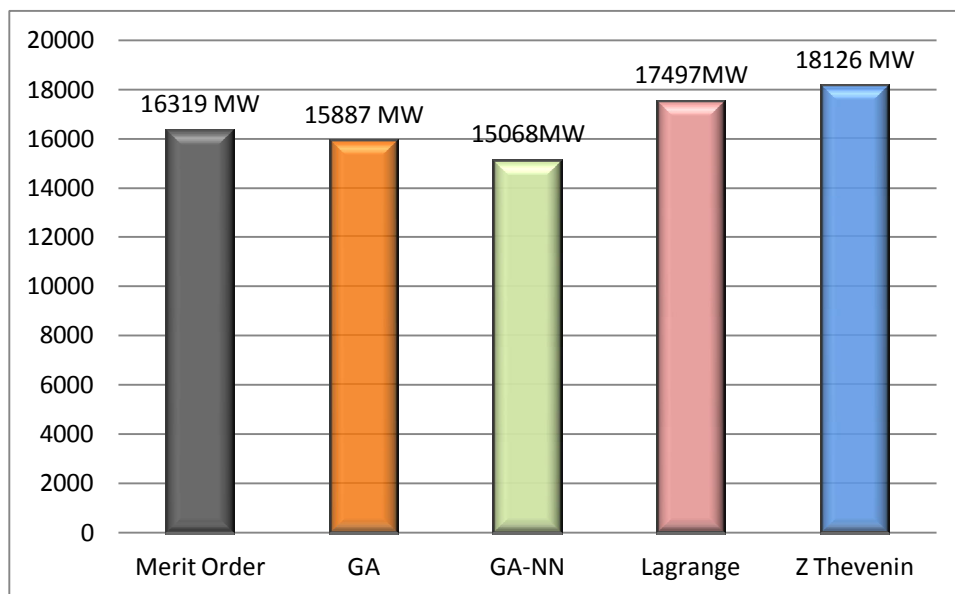

Fig. 8. PV curve of Java-Bali interconnection system for Different Optimization Methods

Table 3. Comparison Of Steady State Stability Limits For Different Methods



Limit of maximum loading is influenced by the value of impedance between the load and generator. Impedance value was smaller, the maximum power transfer increased. This relationship can be seen in the following equation:

$$P = \frac{E_R E_S}{X_T} \sin(\delta_S - \delta_R) \tag{11}$$

Where:

P = Real Power transfer

$E_R$  = Voltage receiver

$E_S$  = Voltage sending

$X_T$  = Reactance Transmission

$\delta_R$  = Angle Bus Receiver

$\delta_S$  = Angle Bus Sending

Using Thevenin impedance method, plant operations adjusted impedance value between the generator and the load point to point. Generator having the smallest impedance values would be prioritized for maximum operating other plants followed by large impedance values obtained.

In Figure 9, the relationship of P to changes in the value of D and E were obtained by the relationship that lower of D value and greater of E value would raise steady state stability limit. In this study, the value of D and E for all the optimization method was being compared. The result showed that thevenin impedance method had the lowest value of D and the largest value of E so that the steady state stability limit for this method was the greatest.

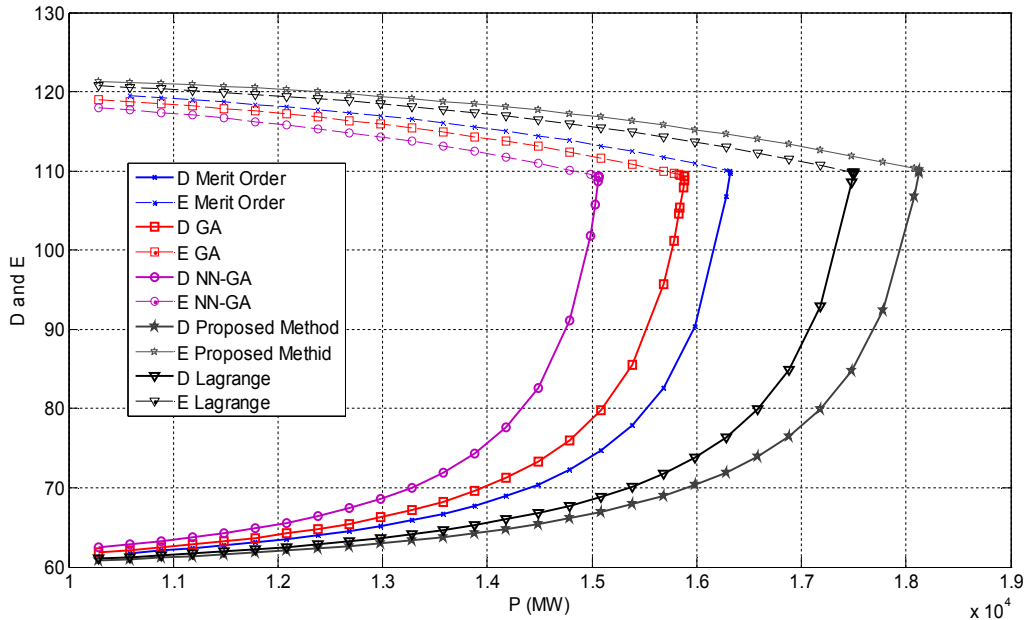

Fig. 9. P vs D and E Variabel

In Figure 10, the gradient of the slope between changes in the power and in the stability index provided information about the stability of the steady state stability. The proposed method had a large gradient so that any changes in power caused a little steady state stability index.

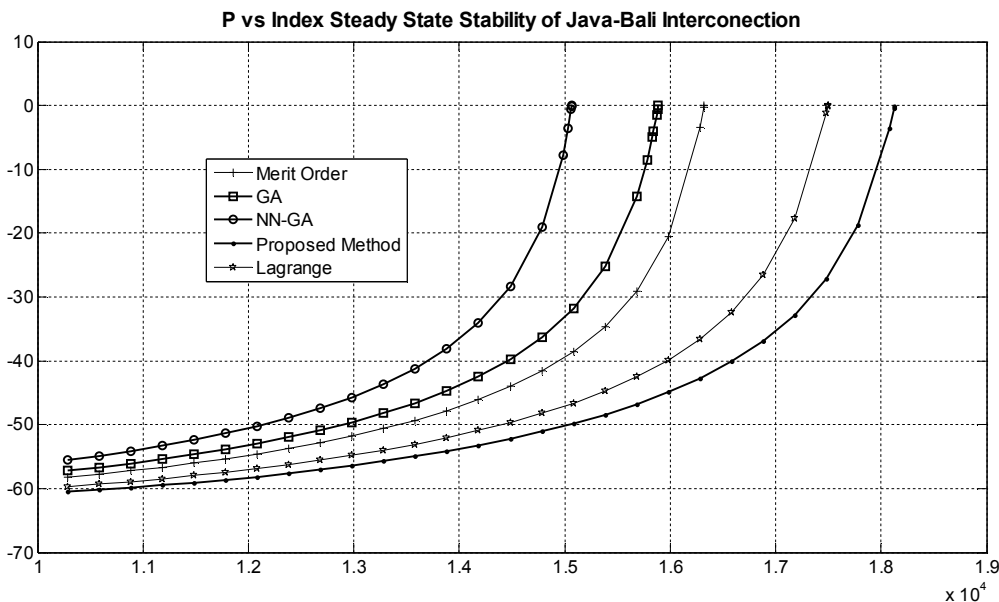

Fig. 10. P vs Index Stability

The relationship between the voltage load center variation and the value of stability index was described in the figure 11. From the figure it was shown that for the same value of load center voltage, it determined different stability indices. The proposed method had the lowest stability index. This provided information that in the event of voltage drop caused by the load on the Load Center would cause a decrease in the stability index that was not too large when compared to other optimization methods. Therefore, at steady state stability studies, using Thevenin impedance operation, would be able to improve the condition of the stability system.

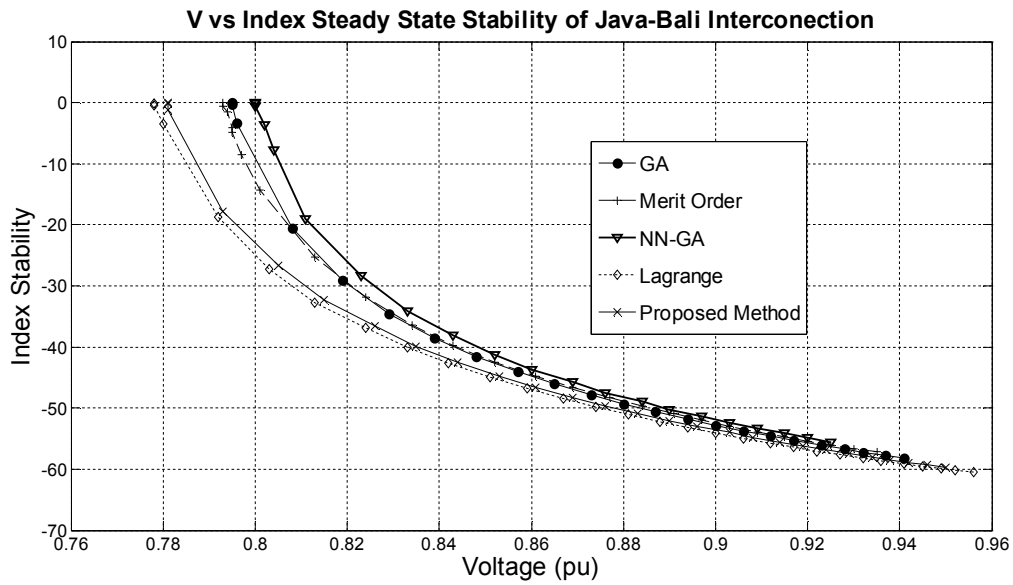

Fig. 11. Voltage vs Index Stability

This load limit is obtained from the Java-Bali system model into the form of Dimo REI equivalent.

$$\frac{d\Delta Q}{dV} = \sum_m \frac{Y_m E_m}{\cos \delta_m} - 2 \left( \sum_m Y_m + Y_{load} \right) V$$

To see the effect of the value of D and E for the steady state stability limit can be seen in the figure 6. Determination of stability power reserve and voltage stability reserve can be determined using the following equation:

$$\text{Power Stability Reserve} = \frac{P_{\max} - P_{\text{base case}}}{P_{\text{base case}}} \times 100\%$$

$$\text{Voltage Stability Reserve} = \frac{V_{\max} - V_{\text{base case}}}{V_{\text{base case}}} \times 100\%$$

On the table 4, thevenin impedance seen that the method has a better security level. Stability margin is left for the initial loading conditions to the unstable conditions of about 76.29% followed by Lagrange Method 70.17%, and Merit Order 58.71%.

Table 4. Comparison Of Reserve Power Systems

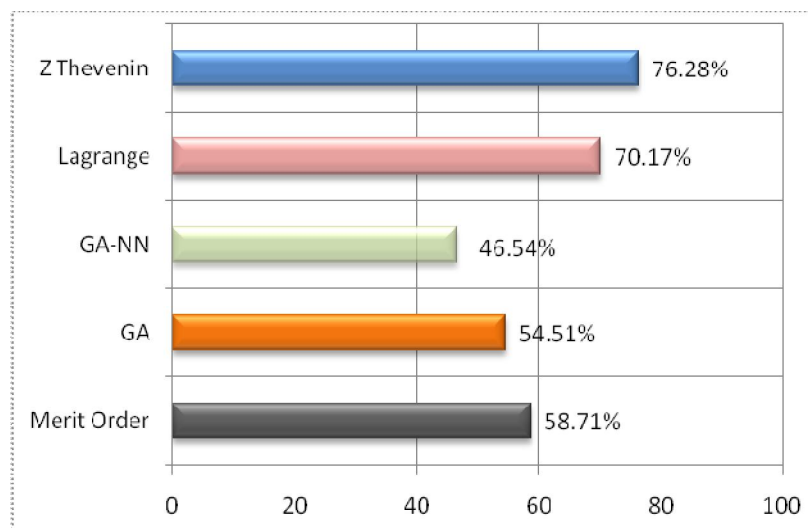

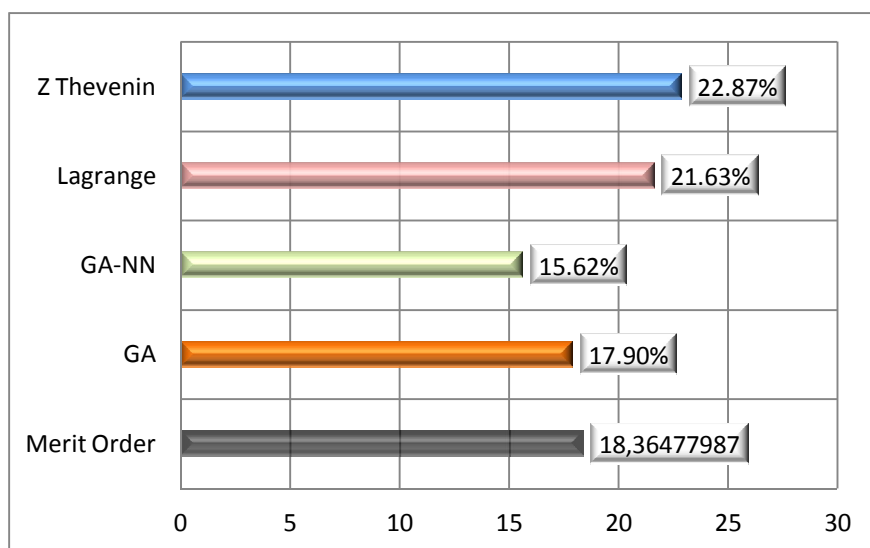
**Table 5.** Comparison of voltage power systems

From Table 5, it was shown that the Thevenin impedance method had a greater margin of voltage stability. This margin is very important in the voltage collapse phenomenon. The greater the margin values were, the further the distance condition of voltage collapse was.

## 6. CONCLUSION

The simulation results showed that the active power rescheduling with proposed method in this paper was able to improve steady state stability index when compared with the other methods such as Merit Order, GA, NN-GA and Lagrange. It could be shown from the increasing of steady state stability limit index. This method was expected to be implemented at the peak load operation or at special events requiring a better level of security and be additional tools to facilitate the generation rescheduling for steady state stability assessment. In the future research it should be compromised between the operational cost and SSSL to obtain the best performances of power system.

## REFERENCES

1. Anderson P. M. and Fouad A. A., *Power System Control and Stability*, Iowa University Press, Ames, Iowa, 1990.
2. Yang Wang, Wenyuan, Jiping Lu, A New node voltage stability index based on local voltage phasors, *Electrical power system research*, pp: 265-271, 2009
3. H.Y. Yamin, Review on methods of generation scheduling in electric power systems, *Electrical power system research*, pp: 227-246, 2004
4. Zarak A.; Bin Othman M.F. A, Implementing Particle Swarm Optimization to Solve Economic Load Dispatch Problem, pp:60-65, 2009
5. Cutsem T.V., An Approach corrective control of voltage instability using simulation and sensitivity, *IEEE Transaction on Power System*, Vol.10, No.2, pp. 616-622, 1995.
6. Wang X., Ejebe G.C., Tong T.,Waight J.G., Preventive corrective control for voltage stability using direct interior point method. *IEEE Transaction on Power System*, Vol.13, No.3, pp.878-883, 1998.
7. Feng Z., Ajjarapu V., Maratukulam D.J., A comprehensive approach for preventive and corrective control to mitigate voltage collapse, Vol.15, No.2, pp. 791-797, 2000.
8. Capitanescu F., Cutsem T.V., Preventive of control of voltage security margins: a multicontingency sensitivity-based approach, *IEEE Transaction on Power System*, Vol.17, No.2 pp. 359-364, 2002
9. Chakrabarti, Jeyasurya, Generation Rescheduling Using ANN-Based Computation of Parameter Sensitivity of Voltage Stability Margin, *Engineering Application of Artificial Intelligence*, Vol.21, pp-1164-1169, 2008.
10. Zhenyu Huang, Lixin Bao, and Wilsun Xu, "A Method to measure QV curves and its Application in Power System," *Electrical Power and Energy Systems*, June 2006, pp. 147-154.
11. Crary S. B., 1945, *Power System Stability*, General Electric Series, Schenectady, New York, Copyright 1945, Third Printing October 1955.
12. P. A. Lof, G. Anderson and D. J. Hill, "*Voltage Stability Indices For Stressed Power System*," *IEEE Trans. on Power Systems*, vol. 8, pp. 326-335, Feb. 1993.
13. Savulescu S. C., "Fast Assessment of the Distance to Instability. Theory and Implementation," in *Real Time Stability in Power Systems*, pp. 31-64, Springer Verlag, Norwell,MA, 2006.

14. Campeanu H. S., L'Helguen, E., Assef, Y., Vidal, N., and Savulescu, S. C., "Real-Time Stability Monitoring at Transelectrica," Paper PSCE06-1288, presented at the "Real- Time Stability Applications in Modern SCADA/EMS" Panel, IEEE PSCE 2006 Atlanta, GA, October 29–November 2, 2006.
15. Savulescu, " Solving Open Access Transmission And Security Analysis Problems With The Short-Circuit Currents Method," Latin America Power 2002 Conference Controlling and Automating Energy Session, Mexico, 2002.